

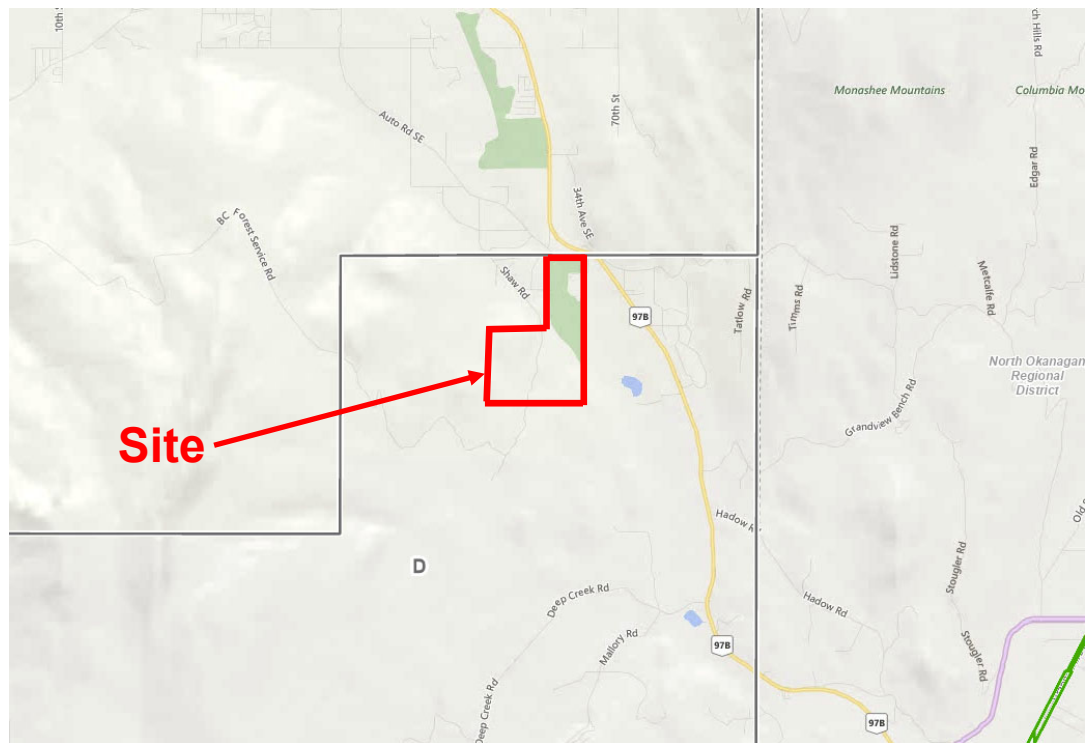

**May 27, 2021**

# PROJECT OUTLINE FOR ZONING BYLAW AMENDMENT APPLICATION

PREPARED FOR: JGS GOLF GROUP LTD. &  
COLUMBIA SHUSWAP REGIONAL DISTRICT



LAWSON ENGINEERING LTD.  
825C Lakeshore Drive W PO Box 106 Salmon Arm, BC V1E 4N2  
[www.lawsonengineering.ca](http://www.lawsonengineering.ca)

## EXECUTIVE SUMMARY

This report outlines the proposed plans to amend Zoning Bylaw 751 as it relates to the property located at 6015 Shaw Road. The subject property is currently zoned Golf Course (GC) in the Electoral Area D, Zoning Bylaw 751.

In accordance with the current zoning, there is an existing golf course, clubhouse / restaurant and parking area onsite. The proposed zoning bylaw amendment would create a “Site Specific Regulation” within the GC zoning typical to Bylaw 751 Section 4.5.5. There is no current definition provided within Bylaw 751 that addresses short term *Seasonal Campsite* rental with no membership requirements. To address this deficiency, the proposed zoning bylaw amendment would adopt the existing definition of *Campgrounds*, as seen in section 1.0 of Zoning Bylaw 825, to be included within the Site Specific Regulation as a secondary use. *Community Water System* and *Community Sewer System* have been included in the zoning amendment as secondary uses within Lot PID 017-896-215 in order to provide servicing to the proposed *Campground*.

Site access is anticipated to be from Shaw Road and will be designed to meet all shared access driveway requirements for the Ministry of Transportation (MoT) and the Columbia Shuswap Regional District (CSRD).

The existing Agriculture (AG) Land Use Designation found in Bylaw 750 “Ranchero / Deep Creek Official Community Plan” (OCP) allows for development which does not affect the lands long term agricultural capability. It is in Lawson Engineering’s opinion that the proposed *Campground* development meets these requirements by way of minimizing removal of vegetative cover and adhering closely to the BC Parks facility standards for *campsite* layout.

We recommend that the Columbia Shuswap Regional District consider this proposal to amend Zoning Bylaw No. 751 to allow a Site Specific Regulation within the southwest portion of 6015 Shaw Road and the addition of *Community Water System* and *Community Sewer System* as secondary uses throughout the subject property.

## **Table of Contents**

<b>INTRODUCTION</b>	<b>1</b>
<b>PROPOSED ZONING BYLAW AMENDMENTS</b>	<b>2</b>
<b>OFFICIAL COMMUNITY PLAN</b>	<b>3</b>
<b>SITE DESCRIPTION</b>	<b>5</b>
<b>PROPOSED LAYOUT</b>	<b>5</b>
<b>SITE ACCESS</b>	<b>5</b>
<b>SITE SERVICES</b>	<b>5</b>
<b>CONCLUSION</b>	<b>6</b>
<b>APPENDIX A: EXISTING &amp; PROPOSED LAND USE SKETCH PLAN</b>	<b>7</b>
<b>APPENDIX B: PRELIMINARY SUBJECT AREA SKETCH PLAN</b>	<b>9</b>
<b>APPENDIX C: PROPOSED ZONING AMENDMENT BYLAW 751</b>	<b>11</b>
<b>APPENDIX D: BC PARKS SDG-T1 &amp; SDG-T2</b>	<b>14</b>

## 1. INTRODUCTION

Lawson Engineering Ltd. (LEL) has reviewed the Columbia Shuswap Regional District Ranchero / Deep Creek Zoning Bylaw No. 751, the Ranchero / Deep Creek Official Community Plan Bylaw No. 750, and the Scotch Creek / Lee Creek Zoning Bylaw No. 825 in regards to the subject property at 6015 Shaw Road. In accordance with the respective bylaws the parcel falls within the Golf Course (GC) zoning and has a Land Use Designation of Agriculture (AG) in the OCP.

This report outlines a proposed amendment to Zoning Bylaw No. 751 which includes a Site Specific Regulation allowing development of a 100 unit *Campground* in the southwestern corner of the site, as well as the inclusion of *Community Water System* and *Community Sewer System* as secondary uses throughout site.

A review of the Official Community Plan Bylaw 750 has been included within this report and outlines the proposed *Campground's* adherence to the existing agriculture (AG) Land Use Designation.

The proposed development site has a total area of 92.66 Ha. The legal description and general information for the property is shown below:

	Legal Description	Parcel Area	Zoning	OCP Designation	PID
<b>Parcel #1</b>	<b>Lot 1, Section 32, Township 19, Range 11, West of the 6<sup>th</sup> Meridian, Kamloops Division Yale District, Plan KAP47991 Except Plan KAP87174</b>	<b>92.66 (ha)</b>	<b>GC</b>	<b>AG</b>	<b>017-896-215</b>

## 2. PROPOSED ZONING BYLAW AMENDMENTS

Following consultation with the CSRD, it is proposed that a Site Specific Regulation in Section 4.15 (Golf Course Zone) of Bylaw 751 allowing for *Campground* use within a defined area, as well as the addition of *Community Water System* and *Community Sewer System* as secondary uses throughout site, be considered for adoption. The proposed Site Specific Regulation would allow *Campgrounds* in the Subject Area as shown on Figure 1 below. For further details on location and preliminary lot layout, see Appendix A: Existing & Proposed Land Use Sketch Plan, and Appendix B: Preliminary Subject Area Sketch Plan.

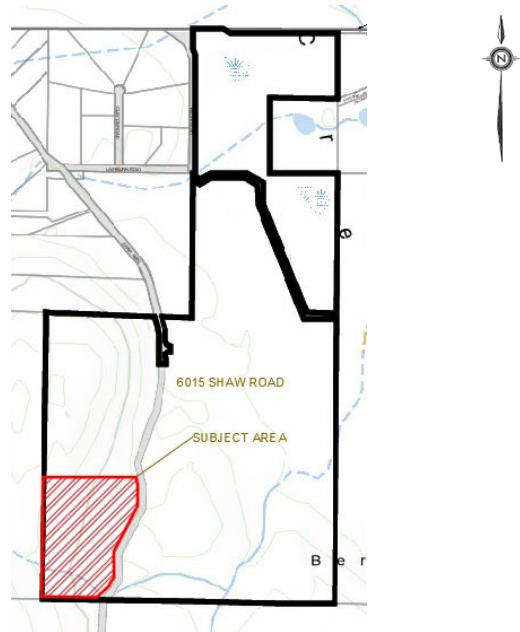

**Figure 1. Site Specific Regulation Area**

*Private Campgrounds* are defined as follows in Bylaw No. 751:

*“Private Campground is the use of land, buildings or structures for the purpose of providing seasonal temporary accommodation in cabins, tents or recreational vehicles on camping spaces, and is not intended for commercial lodging or use by the travelling public. This use may include accessory facilities for eating and assembly purposes, washrooms, bathing and laundry facilities, entrance kiosk, campground manager’s accommodation and is open only to members and their guests for a membership fee;”*

*Campgrounds* are defined as follows in Bylaw No. 825:

*“Campground is the use of land, buildings, and structures for temporary accommodation in tents or recreational vehicles on camping spaces”*

*Private Campground*, as currently defined in Bylaw 751, allows for *seasonal* use by way of membership only. It is the owners intent to allow paid access to the *Campground* facilities to the general public without any membership requirements. To this end, it is proposed that *Campground*, as defined in the Lee Creek Scotch Creek Zoning Bylaw No. 825, be included as a secondary use within the existing Golf Course Zoning by way of a Site Specific Regulation. Additional secondary uses to be included for the purpose of supporting the proposed *Campground* are *Community Water System*, and *Community Sewer System*.

The intent of the zoning bylaw amendment would be to adopt the definition of *Campground* and to adhere to existing regulations found in Bylaw 751 & 825 such as the following:

- Temporary usage (less than 4 consecutive weeks);
- Maximum number of *campsites* to be implemented;
- No cabins included in zoning amendment;
- *Campground* shall only be used on a *seasonal* basis, no residential use is permitted with exception of the *Campground* manager's accommodation; and
- All *Campground* facilities must be serviced by a water and septic system which meet the relevant regulatory requirements.

The proposed Site Specific Regulation would include the definition of *Campground* as per Bylaw 825 which deviates from the existing definition of *Private Campground* as defined in Bylaw 751 in the following ways;

- *Campground* sites are intended to be available to the travelling public at a daily or weekly rate;
- No membership fees required.

It is the opinion of Lawson Engineering that implementation of the above zoning amendments along with the inherently *seasonal* nature of the existing golf course, will help to promote short term *seasonal* use. Additional measures that may be implemented to reduce or eliminate the risk of overstay would include providing gated access to the *Campground* facilities and offseason shutdown of community water and sanitary services. For further information regarding the proposed Golf Course (GC) zoning amendment, see Appendix C: Proposed Zoning Amendment Bylaw 751.

### 3. OFFICIAL COMMUNITY PLAN

The Rancho / Deep Creek Official Community Plan Bylaw No. 750 designates the subject property land use as Agriculture (AG). The portion of land proposed to accommodate the *Campground* is outside the ALR. Within the Agriculture (AG) Land Use Designation *Campgrounds* are not referenced however, the proposed *Campground* use is inline with the objectives and policies laid out in section 3.5 of the Rancho / Deep Creek Official Community Plan in the following ways:

Objective 1) "Maintain the agricultural land base and protect it from activities that may diminish agricultural value and potential."

- *Campgrounds* support Agriculture land use Objective 1 as they are minimally invasive to the agricultural land base. The proposed *Campground* would be *seasonal*, open for a total of no more than 26 weeks per year, during the golfing season only, and with no storage of recreational vehicles permitted during the off-season. The intent of these regulations would be to reduce any foreseeable impact on the existing land base.

Objective 2) "Encourage suitable agritourism opportunities and value-added agriculture."

- The proposed *Campground* will provide opportunity for increased patronage to existing local agritourism sites.

Objective 3) "Support development that is compatible with the Community Values (Section 1.4) and Development Criteria (Section 3.1)."

- The proposed *Campground* adheres to the community values and development criteria laid out in sections 1.4 and 3.1 of Bylaw 750 in the following ways:

- The proposed *Campground* development will require minimal clearing and ground disturbance and maintaining existing vegetative cover and green space by adhering closely to BC Parks standard *campsite* layouts. All topsoil stripping will be stockpiled and respread onsite allowing for ease of future reclamation if required. See Appendix D: BC Parks SDG-T1 & SDG-T2 for further details on individual *campsite* layout.
- A riparian area assessment will be conducted prior to construction and any recommended setbacks from existing water courses adhered to. Current design assumes a 15 meter riparian setback.
- Treated wastewater will meet or exceed all regulatory requirements for water quality, quantity, ground disposal, and setbacks in an effort to protect existing water courses and aquifers.
- The proposed *Campground* development will include a comprehensive drainage plan that will adhere to relevant best management practices including but not limited to the provision of settlement prior to reintroduction to existing waterways.

Objective 4) “Encourage farmers in the Plan Area to follow the measures described in the Farm Practices Guidelines as outlined by the Ministry of Agriculture.”

- Objective 4 is not applicable to the subject properties current or proposed land use.

Policy 1) “Lands within the Agriculture designation are shown as "AG" on Schedule ‘B’.”

- Policy 1 is administrative and not applicable to the proposed development.

Policy 2) “Lands within the Agriculture designation shall be maintained as parcels of at least 60 ha.”

- As the proposed *Campground* shall operate on a *seasonal* short term rental basis and remain under current ownership, subdivision of the subject property will not be required.

Policy 3) “One secondary dwelling unit may be considered in the Agriculture designation, subject to zoning and proof of adequate water and sewer services that meet Provincial regulations.”

- The proposed *Campground* zoning will not include more than the allowable 2 dwellings on the subject parcel. *Campground* development will be for short term, *seasonal* use only. No park model trailers, cabins, or other permanent dwellings shall be permitted within the *Campground*.

Policy 4) “For lands within the ALR, the regulations and policies of the Agricultural Land Commission (ALC) apply. Approval must first be obtained from the ALC where land in the ALR is proposed for subdivision, a second dwelling unit, or a non-farm use.”

- The proposed *Campground* location is situated entirely outside of ALR lands and therefore not subject to ALC approval.

Policy 5) “The Agriculture land use designations encompass agricultural uses, and uses accessory to agriculture. Subject to the guidelines of the Agricultural Land Commission and the zoning bylaw, the following uses are appropriate in lands designated Agriculture: agri-tourism operations, and uses which will not affect the long-term agricultural capability of the land.”

- The proposed *Campground* layout utilizes existing tree cover thereby minimizing clearing and grubbing requirements. all topsoil is to remain onsite for respread or stockpile for future use facilitating any potential future reclamation requirements. the affect of development on long term agricultural capability of the land will be minimized by maintaining existing vegetative cover within the individual *campsites* with the exclusion of minor brush removal and grading.

Policy 6) “Recognize the existing Canoe Creek Golf Course in the current zoning bylaw.”

- Policy 6 is administrative and not applicable to the proposed development.

#### 4. SITE DESCRIPTION

The site is located at 6015 Shaw Road. It is bounded to the North by Auto Road SE and City of Salmon Arm residential lands; on the West by Rural and Resource and Rural Residential land; on the East by Agriculture land and a Mobile Home park, and the South by Rural Resource land.

The proposed development includes one legal parcel that is 92.66 Ha. The parcel is divided by Shaw Road. To the east of Shaw Road exists the golf course, clubhouse / restaurant and parking area. To the west of Shaw Road is bare land. The bare land to the west of Shaw Road has varied land characteristics. The land to the south is moderately flat and potentially accommodates a water course. The land to the north sees steep slope conditions (20-30% slopes) before it plateaus at an elevation of 660m.

#### 5. PROPOSED LAYOUT

Upon zoning approval, the proponent’s plan is to create a *Campground* in the southwest corner of the site. *The Campground* would measure approximately  $\pm 7.6$  ha, include amenity, and green space areas, and be serviced by community water and septic services to be installed by the owner.

The Preliminary Proposed *Campground* Site Plan outlines 93 *campsites*. Individual *campsites* have been designed to BC Parks standard SDG-T1 & SDG-T2. The proposed zoning amendment will allow for up to 100 *campsites* in order to accommodate potential changes to the proposed *Campground* site plan. Final *Campground* site plan to be determined upon completion of detailed design.

The standard single *campsite* measures approximately 17m wide by 21m long, and the standard double *campsite* measures approximately 28m wide by 27m long, with some sites measuring slightly larger. The site plan identifies a potential watercourse through the *Campground* and delineates a 15m setback from the existing water course.

#### 6. SITE ACCESS

Access to the proposed *Campground* development will be off Shaw Road and meet all relevant MoT and CSRD requirements for shared access driveways as listed in section 1420.08 of the 2019 supplement to TAC geometric design guide, and section 7.2 of the CSRD Subdivision Servicing Bylaw No. 641. Individual *campsites* will not have direct access to Shaw Road. A shared access tying in to Shaw Road will provide access to each individual *campsite*. Originally a gravel surfaced road, Shaw Road was upgraded to a paved surface structure at the developer’s expense in 2020.

#### 7. SITE SERVICES

The proposed *Campground* area is not currently serviced by water or septic and will therefore require the establishment of a new onsite septic disposal system as well as a new domestic water service. It is anticipated that water will be sourced from new wells to be located within the property and septic treatment to Class C or better for ground disposal onsite.

It is understood that during third reading of the 2011 rezoning proposal, water use was of primary concern. The 2011 proposed development was of a significantly greater scale, including 444 mixed residential units and one, 50 unit hotel for a total of 494 habitable units designated for year round use. The current proposal includes 100 campsites with RV hookups for seasonal use only. Based on the scale of the current proposed project and the restricted seasonal use, water demand is anticipated to be between 5% and 10% of the 2011 proposed usage. A similar reduction in sanitary treatment and



disposal requirements is anticipated.

Onsite storm water management is anticipated to rely largely on overland flow within ditches. All storm water design shall be performed to Ministry of Transportation standards including, but not limited to, the provision of settlement prior to reintroduction into existing surface drainage routes. The design of new water and sanitary services will comply with all relevant regulatory requirements.

## 8. CONCLUSION

This report outlines the proposed development of a 100 site *Campground* located on property PID# 017-896-215, within CSRD Area D, and the proposed zoning amendments required for development to meet CSRD Area D Zoning Bylaw 751. Bylaw amendments required prior to development include a Site Specific Regulation for the southwest portion of 6015 Shaw Road to include *Campground* as a secondary use, as well as the addition of *Community water system* and *Community sewer system* as secondary uses throughout the site.

No reference is made within the OCP prohibiting *Campground* use under the existing Agriculture (AG) Land Use Designation. The proposed *Campground* layout (see Appendix B: Preliminary Subject Area Sketch Plan) minimizes removal of vegetative cover and maintains stripped topsoil onsite in an effort to minimize the effect on the long term agricultural capability of the property. It is in the opinion of Lawson Engineering that the proposed *Campground* development adheres to the objectives and policies listed in section 3.5 of the Official Community Plan for Area D, reiterated in section 3 of this report, and that no OCP amendment is required.

The proposed *Campground* will have minimal long term effect on the potential agricultural value of the lands, and is anticipated to promote tourism to agricultural and golf course lands.

This report shows that besides the further design and studies required at the development stage, there are no concerns to inhibit this development. We therefore request that the Columbia Shuswap Regional District consider this proposal to amend Zoning Bylaw 751 as per Appendix C to allow for development of a *Campground* within a portion of the Shuswap National Golf Course located at 6015 Shaw Road.

We trust that this report addresses any concerns the CSRD may have with the proposed rezoning of lot PID# 017-896-215 to allow for *Campground* development. Should you have any questions or comments, please contact our office at your earliest convenience.

Sincerely;

Lawson Engineering Ltd.

Prepared by:

Reviewed by:

David Sonmor, P.Eng  
Project Manager

Blake Lawson, P. Eng., Principal  
Project Engineer

## **APPENDIX A: EXISTING & PROPOSED LAND USE SKETCH PLAN**

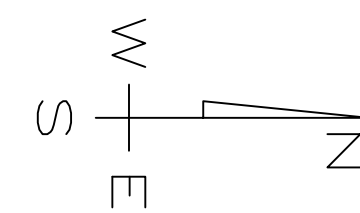

**PROPOSED SEASONAL CAMPGROUND**

**VACANT LAND**

**CLUBHOUSE/ RESTAURANT**

**ACCESS/ PARKING AREA**

**GOLF COURSE**

PID 017-896-215  
 LOT 1, SEC 32, TP, 19, R 9, W6M, KDYD  
 PL KAP47991 EXC PL KAP87174

POTENTIAL WATERCOURSE (TYP.)

EXISTING PROPERTY LINE

EXISTING PAVED ROAD

SHAW ROAD

**LEGEND**

EXISTING	
	HYDRO/TELEPHONE POLE
	HYDRO/TELEPHONE POLE CW DAVIT
	TELEPHONE POLE
	HYDRO POLE
	HYDRO POLE CW TRANS
	POST TOP STREET LIGHT
	GUY
	SANITARY MANHOLE
	STORM MANHOLE
	CATCHBASIN
	FIRE HYDRANT
	GATE VALVE
	SANITARY SEWER
	STORM MAIN
	WATER MAIN
	GAS
	UNDERGROUND TELEPHONE
	FENCE
	DECIDUOUS/EVERGREEN
	HEDGE
PROPOSED	
	SANITARY MANHOLE
	STORM MANHOLE
	CATCHBASIN
	GATE VALVE
	FIRE HYDRANT
	SANITARY SEWER
	STORM SEWER
	WATER MAIN
	DITCH/LINE
	INLET/OUTLET HEADWALL
	END CAP
	WHEEL CHAIR RAMP
	DRIVEWAY LETDOWN

NOTES:  
 1) CONTRACTOR TO VERIFY LOCATION OF ALL EXISTING UTILITIES WITH ALL UTILITY COMPANIES PRIOR TO DIGGING.  
 2) CONTRACTOR TO CO-ORDINATE UTILITY RELOCATION WORKS WITH UTILITY COMPANIES AS REQUIRED.  
 3) ALL CONSTRUCTION TO BE IN ACCORDANCE WITH COLUMBIA SHUSWAP REGIONAL DISTRICT DEVELOPMENT BYLAW N. 641

NO.	DATE YEAR/MM/DD	DESCRIPTION	BY	APPD
2	2021/05/26	ISSUED FOR APPLICATION	FDS	BTL
1	2021/05/12	ISSUED FOR INTERNAL REVIEW	FDS	BTL
0	2019/09/23	ISSUED FOR REVIEW	JSJ	BTL

REVISIONS

NO.	DATE	DESCRIPTION	BY	APPD
DESIGN			FDS	
DRAWN			FDS	
DATE	2021-05-26			
CHECKED			BTL	

BLAKE LAWSON  
 P.ENG  
 SCALES 0 75 150  
 HORIZ. = 1:2500  
 Meter

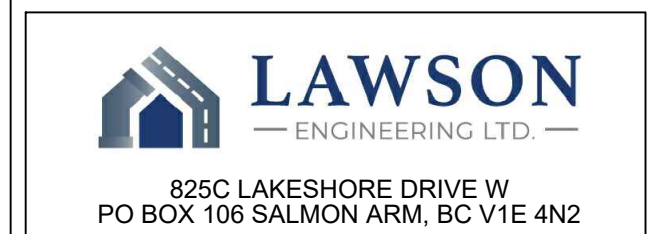

**SHUSWAP NATIONAL GOLF COURSE**

**6015 SHAW ROAD SALMON ARM, BC**

**EXISTING & PROPOSED LAND USE SKETCH PLAN**

PROJECT No.	<b>81-2</b>
SHEET	1 OF 2
DWG. No.	<b>S-1</b>
REV. No.	<b>2</b>

PLOT MAY 28, 2021 COMPUTER: 12 PROJECTS: 812 - RV PARK1 - CIVIL ENGINEERING DRAWINGS 1 - DESIGN: 2021-05-12 DWG (REF: DWG-NAMES)

## **APPENDIX B: PRELIMINARY SUBJECT AREA SKETCH PLAN**

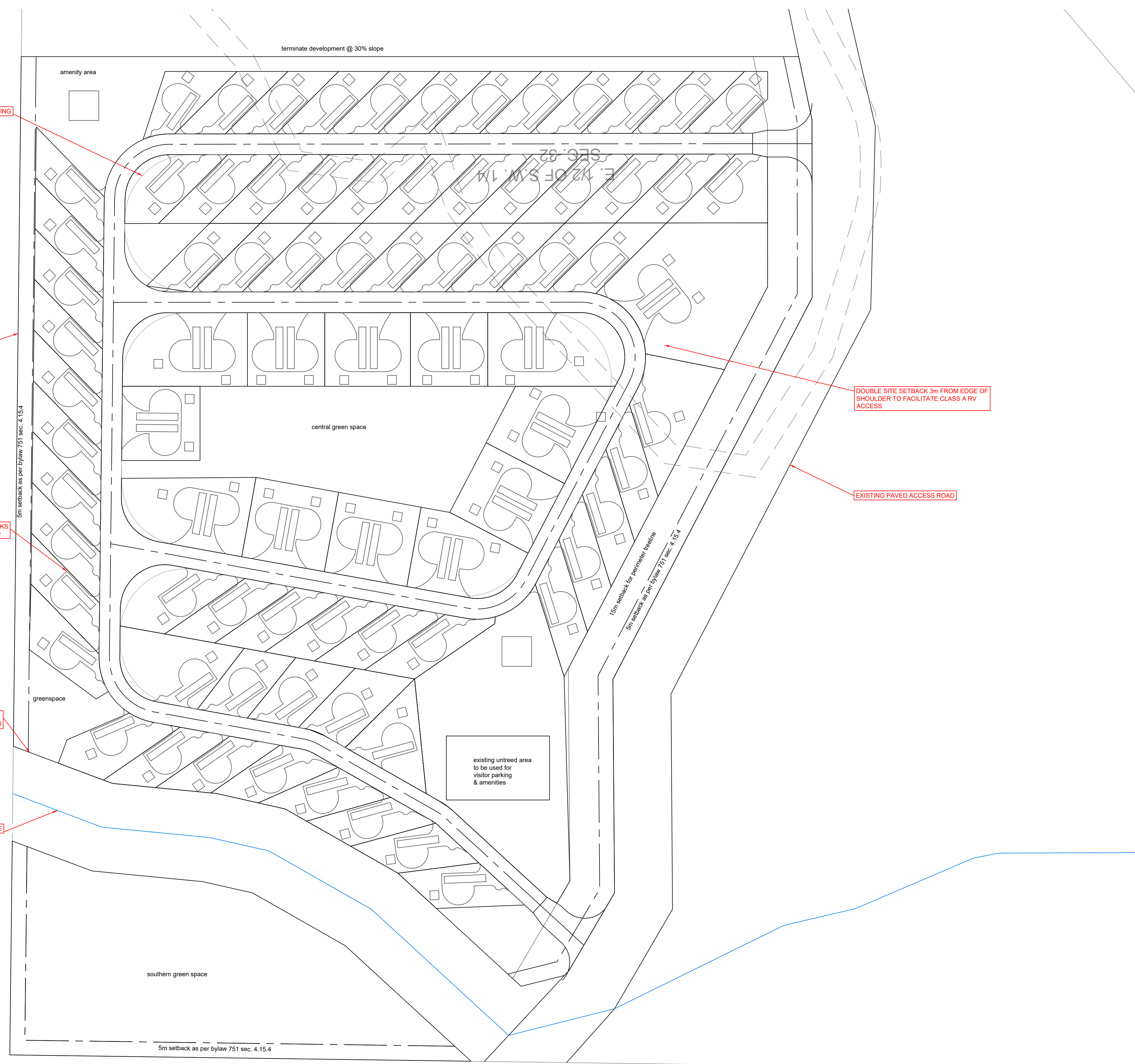
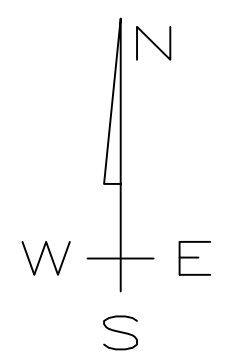

SHOULDER WIDENING

EXISTING PROPERTY LINE

CAMPSITE DESIGN BASED ON BC PARKS STANDARD DETAILS SDG-T1 & SDG-T2

15.0m SPEA SETBACK (APPROX.)

EXISTING WATER COURSE

DOUBLE SITE SETBACK 3m FROM EDGE OF SHOULDER TO FACILITATE CLASS A RV ACCESS

EXISTING PAVED ACCESS ROAD

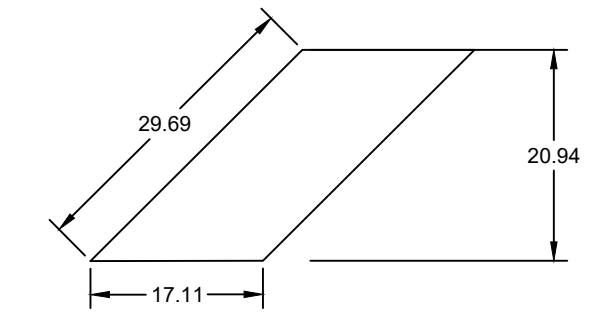

typ. single campsite area = 395 m<sup>2</sup>

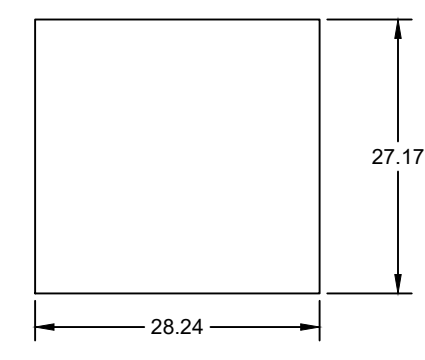

typ. double campsite area = 765 m<sup>2</sup>

**LEGEND**

- EXISTING**
- HYDRO/TELEPHONE POLE
  - HYDRO/TELEPHONE POLE CW DAVIT
  - TELEPHONE POLE
  - HYDRO POLE
  - HYDRO POLE CW TRANS
  - POST TOP STREET LIGHT
  - GUY
  - SANITARY MANHOLE
  - STORM MANHOLE
  - CATCHBASIN
  - FIRE HYDRANT
  - GATE VALVE
  - SANITARY SEWER
  - STORM MAIN
  - WATER MAIN
  - GAS
  - UNDERGROUND TELEPHONE
  - FENCE
  - DECIDUOUS/EVERGREEN
  - HEDGE
- PROPOSED**
- SANITARY MANHOLE
  - STORM MANHOLE
  - CATCHBASIN
  - GATE VALVE
  - FIRE HYDRANT
  - SANITARY SEWER
  - STORM SEWER
  - WATER MAIN
  - DITCHLINE
  - INLET/OUTLET HEADWALL
  - END CAP
  - WHEEL CHAIR RAMP
  - DRIVEWAY LETDOWN

**NOTES:**  
 1) CONTRACTOR TO VERIFY LOCATION OF ALL EXISTING UTILITIES WITH ALL UTILITY COMPANIES PRIOR TO DIGGING.  
 2) CONTRACTOR TO CO-ORDINATE UTILITY RELOCATION WORKS WITH UTILITY COMPANIES AS REQUIRED.  
 3) ALL CONSTRUCTION TO BE IN ACCORDANCE WITH COLUMBIA SHUSWAP REGIONAL DISTRICT DEVELOPMENT BYLAW N. 641

NO.	DATE	DESCRIPTION	BY	APPD
2	2021/05/26	ISSUED FOR APPLICATION	FDS	BTL
1	2021/05/12	ISSUED FOR INTERNAL REVIEW	FDS	BTL
0	2019/09/23	ISSUED FOR REVIEW	JSJ	BTL

REVISIONS

<b>DRAFT</b>	DESIGN	FDS
	DRAWN	FDS
	DATE	2021-05-26
	CHECKED	BTL

BLAKE LAWSON  
 P.ENG  
 SCALES 0 22.5 45  
 HORIZ. = 1:750  
 Meter



**SHUSWAP NATIONAL GOLF COURSE**

**6015 SHAW ROAD SALMON ARM, BC**

**PRELIMINARY SUBJECT AREA SKETCH PLAN**

PROJECT No.	<b>81-2</b>
SHEET	2 OF 2
DWG. No.	<b>S-2</b>
REV. No.	<b>2</b>

PLOT May 28, 2021 12:00 PM C:\PROJECTS\81-2 - RV PARK1 - CIVIL ENGINEERING\DRAWINGS\1 - DESIGN\81-2 - SHUSWAP NATIONAL CAMPGROUND - DESIGN - 2021-05-12.DWG (REF-DWG-NAMES)

**APPENDIX C: PROPOSED ZONING AMENDMENT BYLAW 751**

## .1 Intent

To accommodate private commercial golf courses and associated uses such as driving range and clubhouse.

## .2 Principal Uses

The *uses* stated in this subsection and no others are permitted in the GC zone as *principal uses*, except as stated in Part 3: General Regulations:

- (a) *agriculture*, permitted only on those *parcels* within the *Agricultural Land Reserve*
- (b) *golf course*

## .3 Secondary Uses

The *uses* stated in this subsection and no others are permitted in the GC zone as *secondary uses*, except as stated in Part 3: General Regulations:

- (a) *accessory use*
- (b) *agri-tourism* (permitted only on those *parcels* within the *Agricultural Land Reserve*)
- (c) *clubhouse*
- (d) *community water system*
- (e) *community sewer system*

## .4 Regulations

On a *parcel zoned* GC, no land shall be *used*; no *building* or *structure* shall be constructed, located or altered; and no plan of *subdivision* approved; that contravenes the regulations stated in this subsection, except as stated in Part 3: General Regulations and Part 5: Parking and Loading Regulations.

COLUMN 1 MATTER REGULATED	COLUMN 2 REGULATION
(a) Minimum parcel size created by subdivision	60ha
(b) Minimum parcel width created by subdivision	20 m
(c) Maximum parcel coverage	25%
(d) Maximum height for: <ul style="list-style-type: none"> <li>• principle buildings and structures</li> <li>• Accessory buildings</li> </ul>	<ul style="list-style-type: none"> <li>• 11.5 m</li> <li>• 10 m</li> </ul>
(e) minimum setback from all parcel boundaries	<ul style="list-style-type: none"> <li>• 5 m</li> </ul>

## .5 Screening

All outside industrial storage, including the storage of garbage, shall be completely contained within a *landscape screen* of not less than 2 m in height.

## .6 Site Specific Regulation

In this subsection, lands are described by legal description and by map. In the event of any discrepancy between the legal; description of the lands and the map, the map governs.

(a) In addition to the *secondary uses* in subsection 4.15(3) of this Bylaw, the *secondary uses* on Lot 1, Section 32, Township 19, Range 11, West of the 6<sup>th</sup> Meridian, Kamloops Division Yale District, Plan KAP47991 Except Plan KAP87174 {Shuswap National Golf Course} shall include *Campground* on the portion the subject property shown shaded on the map below. The following regulations also apply:

- (i) *Campground* to be defined as per Bylaw 825 as follows; *Campground* is the use of land
  - buildings and structures for temporary accommodation in tents or recreational vehicles
  - on camping spaces
- (ii) maximum number of *camping spaces* is 100;
- (iii) *Campground* shall only be used on a *seasonal* basis, no *residential use* is permitted with exception of the *Campground* manager's accommodation; and
- (iv) all *Campground* facilities must be serviced by a water and septic system which meet the relevant regulatory requirements.

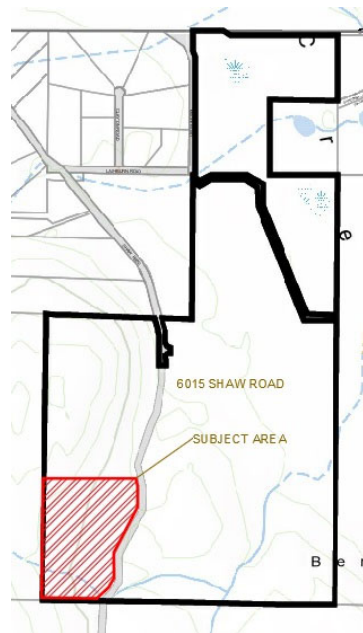



**APPENDIX D: BC PARKS SDG-T1 & SDG-T2**

**NOTES:**

HATCHED AREA REPRESENTS THE 'ACTIVITY AREA', WITHIN WHICH THE PICNIC TABLE AND FIRE RING ARE TO BE LOCATED. SITE SPECIFIC FACTORS INCLUDING:

- VIEWS
- PREVAILING WINDS
- SAFETY

WILL DETERMINE THE EXACT LOCATION OF THESE FACILITIES

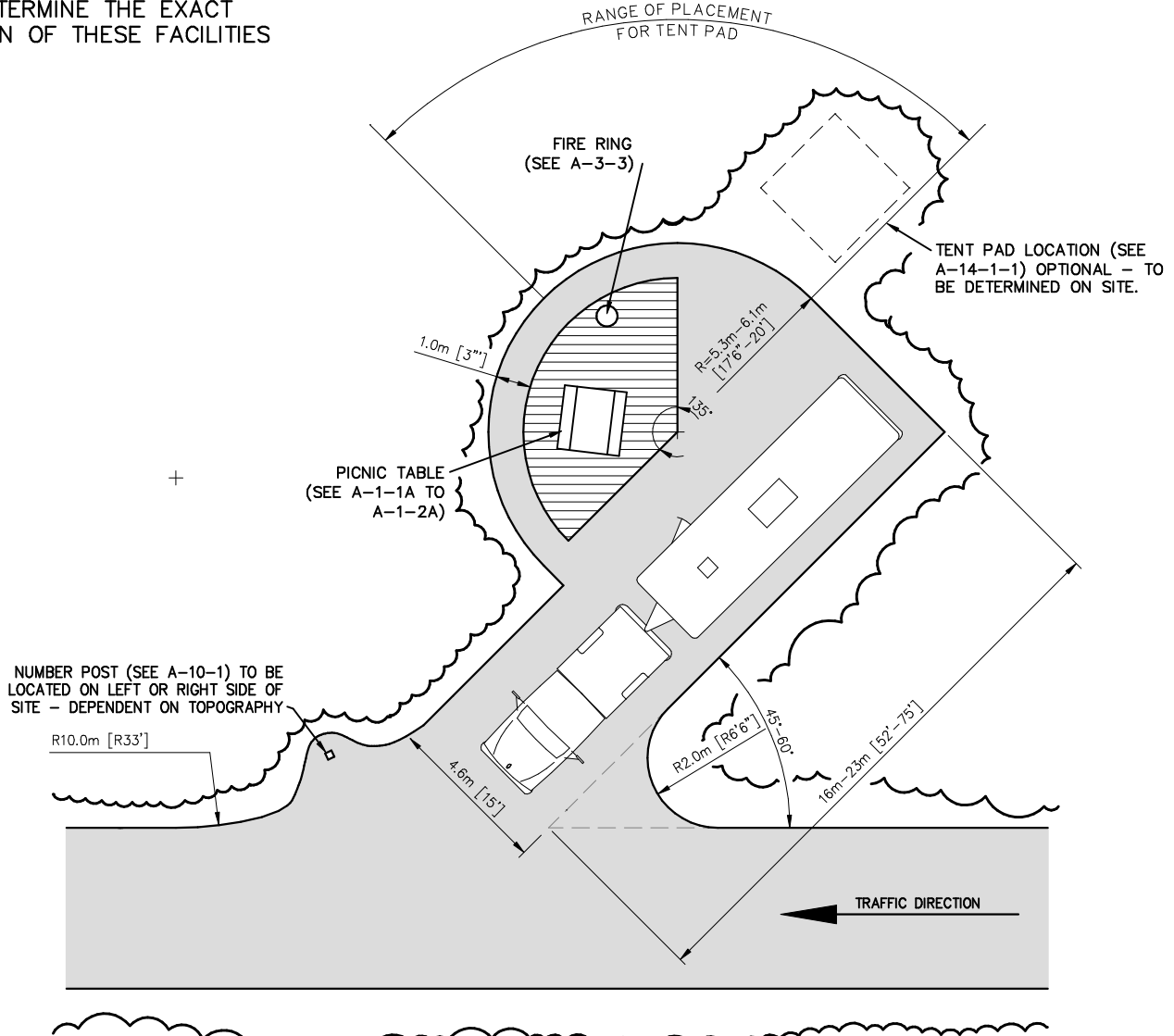

**PROVINCE OF BRITISH COLUMBIA - PROVINCIAL PARKS - FACILITY STANDARDS**

DATE	REVISED BY	REVISION
MAR., 99	USL	DRAWING UPDATE

**SECTION: GROUNDS & LAYOUT - 82100-20  
SINGLE SITE - TYPE 1**

DESIGN BY:	SHEET <b>1 of 1</b>	DRAWING No. <b>SDG-T1</b>
DESIGN DATE:		

**NOTES:**

HATCHED AREA REPRESENTS THE 'ACTIVITY AREA', WITHIN WHICH THE PICNIC TABLE AND FIRE RING ARE TO BE LOCATED. SITE SPECIFIC FACTORS INCLUDING:

- VIEWS
- PREVAILING WINDS
- SAFETY

WILL DETERMINE THE EXACT LOCATION OF THESE FACILITIES

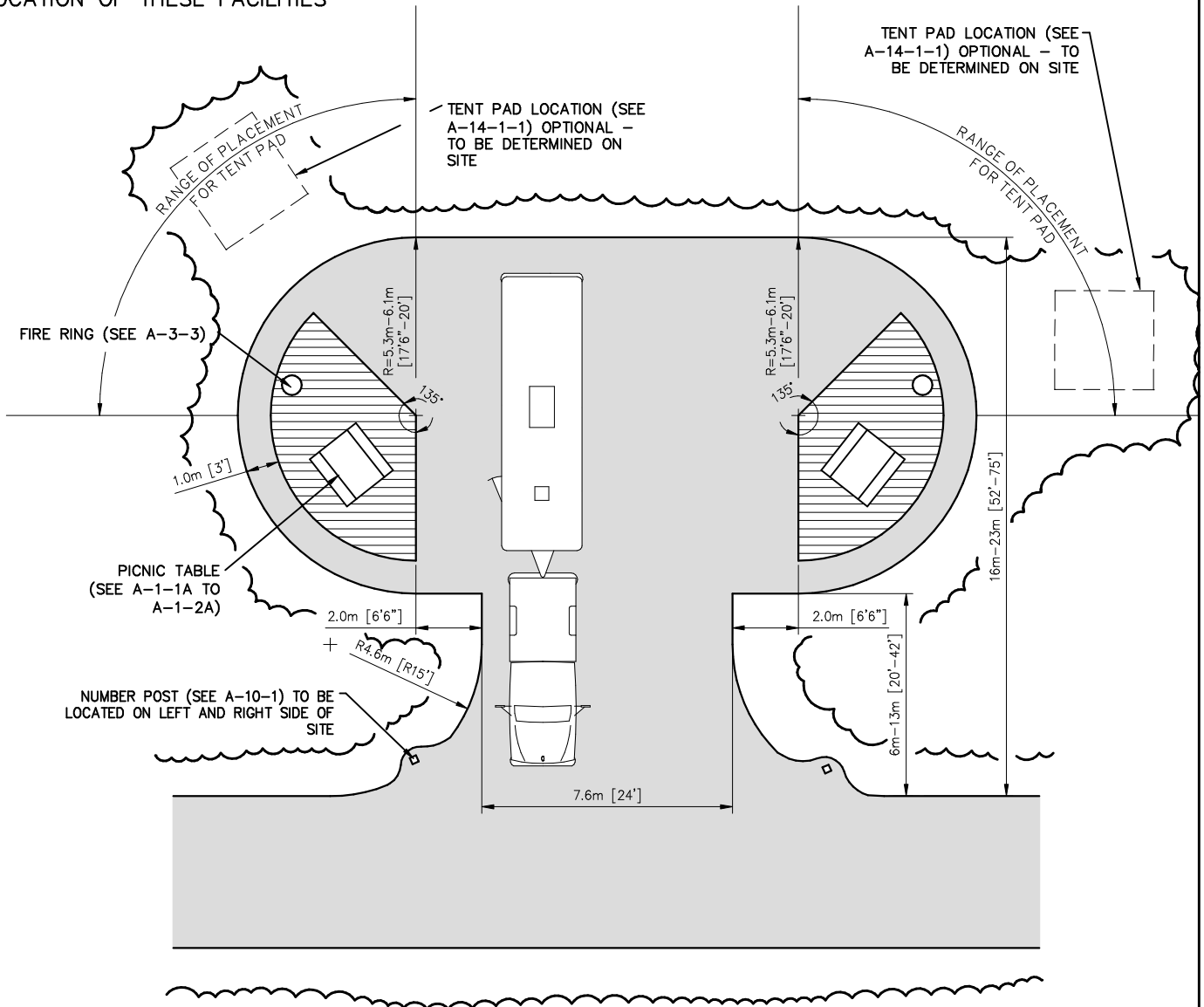

**PROVINCE OF BRITISH COLUMBIA - PROVINCIAL PARKS - FACILITY STANDARDS**

DATE	REVISED BY	REVISION
MAR., 99	USL	DRAWING UPDATE

**SECTION: GROUNDS & LAYOUT - 82100-20  
DOUBLE SITE - TYPE 2**

DESIGN BY:	SHEET	DRAWING No.
DESIGN DATE:	1 of 1	SDG-T2